

# REEL HKV 100

13 Fine wire reels, 02 Spools with conical flanges



Reusable

Winding material : Stainless steel wires, Enamelled copper wire, Alloy wires, Stranded wires

Material : ABS, PS, PS TSG

Standard winding volume : 390 cm<sup>3</sup>

Central bore Ø : 16 mm

Catalogue categorization: 13 , 02

DIN EN 60264-5-1 Cylindrically barrelled delivery spools and conical flanges - dimensions

DIN EN 60264-5-2 Cylindrically barrelled delivery spools and conical flanges - specification for reusable

## TECHNICAL DATA - SPOOLS

### Spools

Flange Ø	Barrel Ø	Central bore Ø	Width	Winding width	Flange thickness	Winding-volume	Central bore Ø tapered part	Drive-hole/pin	Drive-distance
d1 [mm]	d2 [mm]	d3 [mm]	L1 [mm]	L2 [mm]	S [mm]	V [cm <sup>3</sup> ]	d4 [mm]	d5 [mm]	E1 [mm]
100	56	16	100	49	25.5	390	19.5		

### Container

Designation	Outer Ø	Overall height	Inner Ø bottom	Inner Ø top	
	d1 max	h1 max	d2	d3	h2 min
Container VD 100	107	105.5	-	-	-

## PACKAGING

Designation	Cardboard box	Cardboard box weight	Cardboard box Outside Deminsions	Pallets	Pallet weight	Pallet's external dimensions
	piece	kg	cm	piece	kg	cm
Reel HKV 100	160	22	52x52x45	-	-	
Container VD 100	144	9.3	68x44x74	-	-	

**Important:**

If pallet packaging is indicated, this is the preferred method of packing the spools. Please note that the pallets must not be stored in direct sunlight, as the heat build-up may cause the plastic to warp permanently.

## TECHNICAL DRAWING

### Spools

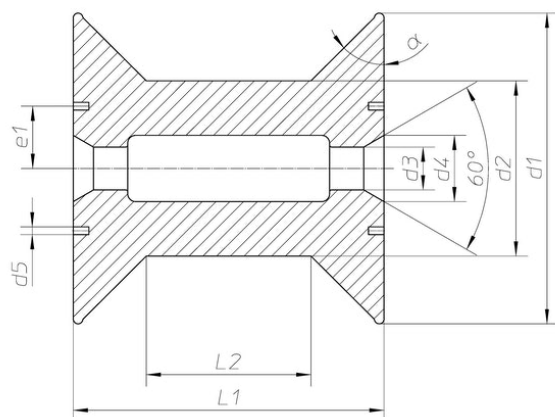

### Container

